

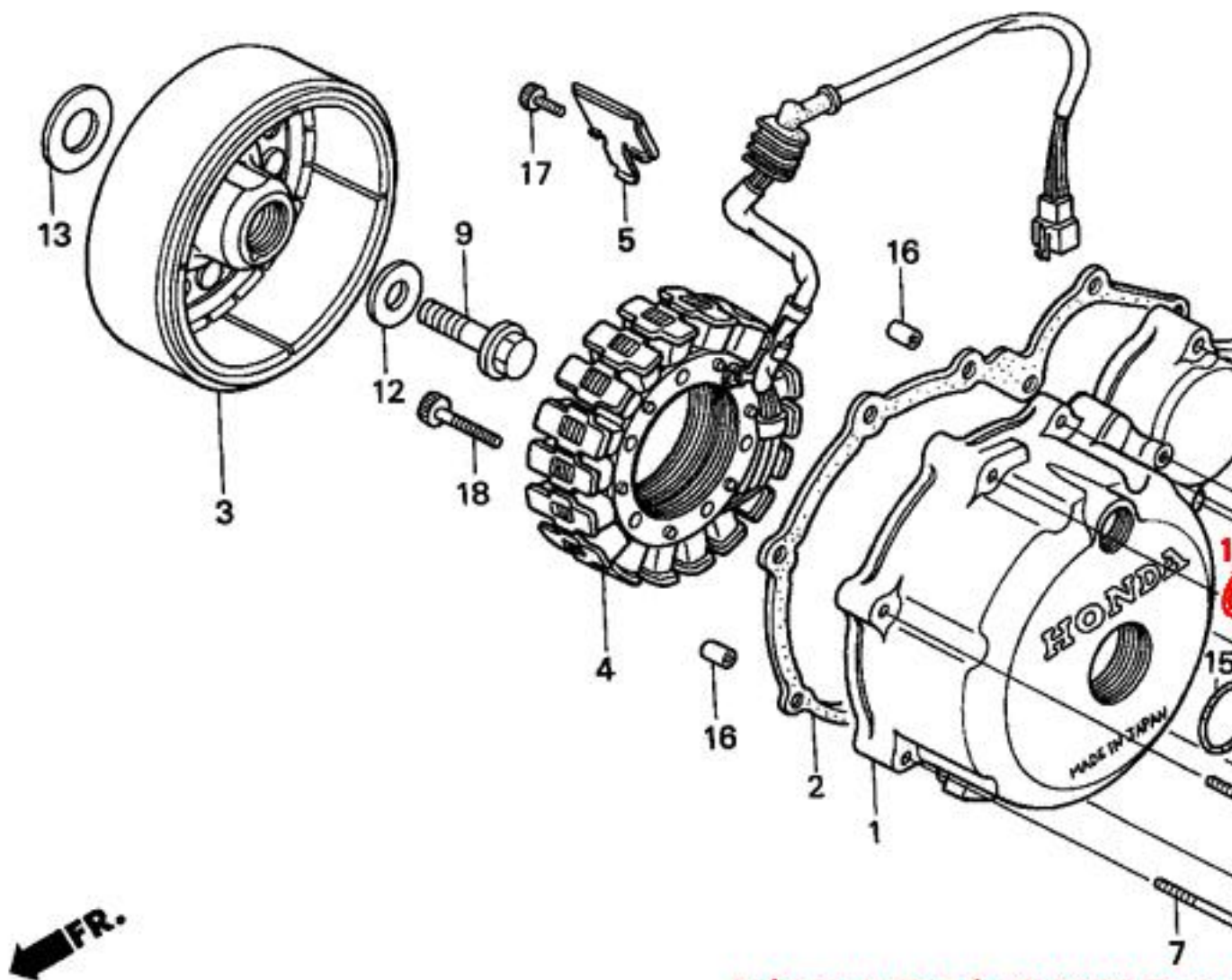

Oring, uszczelniacz korka inspekcji w pokrywie alternatora - zamiennik

Nr OEM Honda: 91303-377-000



Schemat: Honda XL600V Trans

Zastosowanie m.in. Honda:

- CB1300 Super Four
- CH125 Elite / Spacy
- FES125 Pantheon / S-Wing
- FES150 Pantheon / S-Wing
- GL1500 Gold Wing
- F6C Valkyrie
- NSS250 Jazz / Forza / Reflex
- VF500 Magna V30 / Interceptor
- VF700 Magna / Interceptor / Sabre
- VF750 Magna / Interceptor / Sabre
- [VT1100 Shadow](#)
- [VT750 Black Widow / Shadow](#)
- CBR600
- VTR1000 Superhawk / Firestorm
- CB300F
- CBR300R

- CMX300 Rebel
- [CRF1000 Africa Twin](#)
- RC1000VS
- ANF125 Innova
- ATC250ES Big Red
- C70 CUB
- C90 CUB
- CA125 Rebel
- CB1000
- CB125
- CB250 Two Fifty / Nighthawk
- CB400
- CB-1
- CB50
- CB500
- CB650
- CBF250
- CBF500
- CBR1000
- CBR125
- CBR250
- CBR500
- CD250
- CG125
- CH150 Elite
- CH250 Elite
- CLR125 City Fly
- CM125
- CM250
- CMX250 Rebel
- CN250 Helix
- CN250 Spazio
- CR250
- CRF150
- CRF150F
- CRF230
- CRF250
- CRF450
- CRM125
- CT110
- CTX1300
- CTX700
- FES250 Foresight
- FJS400 Silver Wing
- FJS600 Silver Wing
- FL400
- FMX650
- FSC600 Silver Wing
- FT500
- FX650 Vigor
- GB500
- MSX125 Grom
- NC700
- NES125
- NES150

- NSA700
- DN-01
- NSR125
- NSS300 Forza
- NT650 Deauville / Hawk GT
- NT700 Deauville
- NTV600 Revere
- NTV650 Revere
- [NX125](#)
- [NX250](#)
- [NX500 Dominator](#)
- [NX650 Dominator](#)
- PES125
- PS125
- PES125
- PS150
- PS250 Big Ruckus
- RVT1000R
- SES125 Dylan
- SES150 Dylan
- SH125
- SH150
- SH300
- SLR650
- ST1300 Pan-European
- TL125
- TLR200
- TR200 Fat Cat
- UH125D
- VF1000
- [VT125 Shadow](#)
- [VT700 Shadow](#)
- [VT800 Shadow](#)
- XBR500
- [XL1000V Varadero](#)
- XL125 Varadero
- XL185
- XL200
- XL250
- XL350
- XL500
- [XL600V Transalp](#)
- XL600R
- [XL650V Transalp](#)
- [XL700V Transalp](#)
- XLR125
- XLX350
- XR125
- XR185
- XR200
- XR250
- XR350
- XR400
- XR500
- XR600

- XR650
- [XR650 Africa Twin](#)
- [XR750 Africa Twin](#)

ID 2511